



Control head for decentralised automation of ELEMENT process valves

- Contact-free inductive valve position registration (Teach function)
- Colour illuminated status display
- Integrated pilot air duct in the actuator
- AS-Interface, IO-Link, Bürkert system bus (büS)
- With ATEX II cat. 3G/D approval

Product variants described in the data sheet may differ from the product presentation and description.

Can be combined with

	Type 2100 ▶ Pneumatically operated 2/2-way angle seat valve ELEMENT for decentralised automation
	Type 2101 ▶ Pneumatically operated 2/2-way globe valve ELEMENT for decentralised automation
	Type 2103 ▶ 2/2-way diaphragm valve with pneumatic stainless steel actuator (Type ELEMENT) for decentralised automation
	Type 2104 ▶ T-diaphragm valve with pneumatic actuator in stainless steel (Type ELEMENT) for decentralised automation
	Hygienic process valves

Type description

The device key 8695 control head is designed for decentralised automation of ELEMENT Type 21xx pneumatic process valves with smaller nominal diameters. The valve position is registered via contact-free, analogue sensor element which automatically detects and saves the valve end position via the Teach function during start-up. The integrated pilot valve controls single or double-acting actuators. The design of the control head and actuator is specially configured for the requirements of hygienic process environments and enables internal pilot air duct routing without external piping. In addition to the electrical position feedback, the device status is shown directly on the control head itself via coloured LEDs. An optional AS-Interface communication interface can be selected. The housing is easy to clean and features proven IP protection and chemically resistant materials for use in hygienic processing in the food, beverage and pharmaceutical industries. Combined with Bürkert ELEMENT actuators, the pneumatic actuating system enables spring chamber aeration that avoids actuator chamber contamination from the environment.

Table of contents

1. General technical data	3
1.1. Control head Type 8695.....	3
1.2. Without fieldbus communication: 24 V DC.....	4
1.3. With fieldbus communication: AS-Interface	4
1.4. With digital communication: IO-Link.....	5
1.5. With digital communication: Bürkert system bus (büS).....	5
2. Materials	6
2.1. Material specifications	6
3. Dimensions	6
3.1. Mounting on process valve ELEMENT Type 21xx.....	6
4. Device/Process connections	7
4.1. Electrical connections.....	7
Without fieldbus communication 24 V DC.....	7
AS-Interface connection	7
IO-Link connection.....	7
Bürkert system bus (büS) connection.....	8
5. Product installation	9
5.1. Combination options with pneumatic process valves	9
6. Ordering information	10
6.1. Bürkert eShop – Easy ordering and quick delivery.....	10
6.2. Bürkert product filter	10
6.3. Ordering chart.....	10
6.4. Ordering chart Accessories	11
Standard accessories	11
Adapter kits.....	11

1. General technical data

1.1. Control head Type 8695

Product properties	
Dimensions	Detailed information can be found in chapter "3. Dimensions" on page 6.
Material	
Body	PPS, stainless steel
Seal	EPDM
Cover	PC
Operation	
Operating keys	2
Service interface	Connected to PC via USB connection
Configuration tool	Bürkert Communicator
Commissioning	
Setting valve end position	Automatic using Teach-Function or manual (for device version without pilot valve)
Status display	
Display of device and valve status	Coloured LEDs
Communication	
Fieldbus	AS-Interface
Digital	IO-Link, Bürkert system bus (based on CANopen)
Performance data	
Position sensor	
Analogue position sensor	Inductive (contactless) with self-adjusting switching points (PNP) (NPN on request)
Stroke range for linear actuator	
Valve spindle	2.5...32 mm
Electrical data	
Operating voltage	24 V DC ± 25 %, UL: NEC Class 2
Residual ripple for DC	10 %
Power consumption	< 2 W
Protection class	3 acc. to DIN EN 61140
Electrical connection	
Multipole version	Circular plug M12
Pneumatic data	
Control medium	
	Neutral gases, air, quality class acc. to ISO 8573-1
Dust content	Class 7 (< 40 µm particle size)
Particle density	Class 5 (< 10 mg/m ³)
Pressure dew point	Class 3 (< -20 °C)
Oil content	Class X (< 25 mg/ m ³)
Supply pressure	0...7 bar ¹⁾
Pilot air port	Threaded connection G 1/8 Stainless steel
Actuating system	
Circuit function	Single and double-acting
Air capacity	7 l _N /min (for aeration and ventilation) (Q _{Nn} -value acc. to definition at pressure drop from 7 to 6 bar absolute)
Actuator series/size	Type 21xx, Ø actuator 50 mm
Approvals and certificates	
Conformity	EMC directive 2014/30/EU
Ignition protection	II 3D Ex tc IIIC T135 °C Dc II 3G Ex ec IIC T4 Gc
UL	cULus Certificate; E238179
ATEX	II 3D Ex tc IIIC T135 °C Dc II 3G Ex ec IIC T4 Gc Certificate; BVS 14 ATEX E 008 X
IECEX	Ex tc IIIC T135 °C Dc Ex ec IIC T4 Gc Certificate; IECEX BVS 14.0009 X
CCC (China Compulsory Certificate)	For devices with Ex approval

Environment and installation**Operating conditions****Ambient temperature**

With pilot valve - 10...+55 °C

Without Pilot valve -20...+60 °C

Degree of protection IP65/IP67 acc. to EN 60529, 4X acc. to NEMA 250 Standard

Operating altitude 2000 m above sea level

Installation and mechanical data

Installation variant Direct mounting

Installation position As required, preferably with actuator in upright position

Valve actuator (type, size) ELEMENT Actuator series Type 21xx, actuator size 50 mm and third-party actuators

Adapter kit Detailed information can be found in chapter **"Adapter kits"** on page 11.

1.) The supply pressure must be 0.5 to 1 bar above the minimum required pilot pressure of the valve actuator.

1.2. Without fieldbus communication: 24 V DC**Electrical data**Operating voltage 24 V DC \pm 25 %

UL: NEC Class 2

Residual ripple with DC 10 %

Power consumption Power consumption or power requirement incl. load on an active digital output:
2 W / 5 W**Electrical connection**

Multipole M12, 8-pin

Outputs Max. 100 mA per output

1.3. With fieldbus communication: AS-Interface**Product properties**

Profile S-B.A.E. (A/B slave, max. 62 slaves/master) Certificate No. 87301 acc. to version 3.0

Electrical data**Operating voltage** 29.5...31.6 V DC, UL: NEC Class 2

With bus cable Acc. to specification

Separated from bus signal On request

Power consumption Devices without external power supply

Max. Current consumption 120 mA

Current consumption in normal operation 90 mA (after current reduction; valve + 1 end position achieved)

Electrical connection M12, 4-pin

OutputsContact rating \leq 1 W over AS-Interface

Watchdog function Integrated

1.4. With digital communication: IO-Link

Electrical data	
Electrical connection	M12 × 1, 5-pin, A-coded
IO-Link specification	V1.1.2
SIO-Mode	No
VendorID	0x0078, 120
DeviceID	See IODD file (The IODD file can be downloaded from our website ▶, see Software > Device Description Files)
Transmission rate	230.4 kbit/s (COM 3)
Data storage	Yes
Max. cable length	20 m
Port class	A and B
Power supply	Over IO-Link
Port Class A	
Operating voltage	24 V DC ± 25 % (according to specification)
Current consumption	max. 150 mA
Port Class B	
Operating voltage	
System supply (Pin 1+3)	24 V DC ± 25 % (according to specification)
Actuator supply (Pin 2+5)	24 V DC ± 25 % (according to specification)
Current consumption	
System supply (Pin 1+3)	max. 100 mA
Actuator supply (Pin 2+5)	max. 50 mA

1.5. With digital communication: Bürkert system bus (bÜS)

Electrical data	
Operating voltage	18...30 V DC (acc. to specification)
Electrical connection	M12 × 1, 5-pin, A-coded
Current consumption	Max. 150 mA

2. Materials

2.1. Material specifications

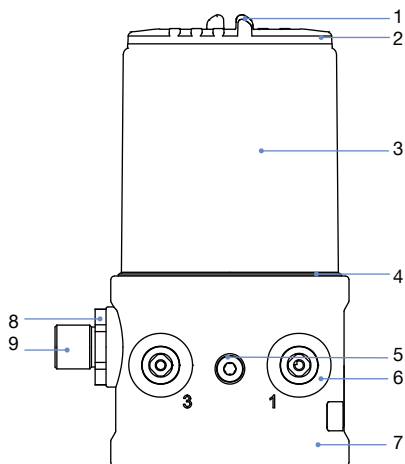

No.	Element	Material
1	Cover	PC
2	Seal	EPDM
3	Body casing	Stainless steel
4	Seal	EPDM
5	Screws	Stainless steel
6	Push-in connector Threaded ports G 1/8	POM/Stainless steel Stainless steel
7	Basic housing	PPS
8	Screws	Stainless steel
9	Plug connector M12	Stainless steel

3. Dimensions

3.1. Mounting on process valve ELEMENT Type 21xx

Note:

Dimensions in mm

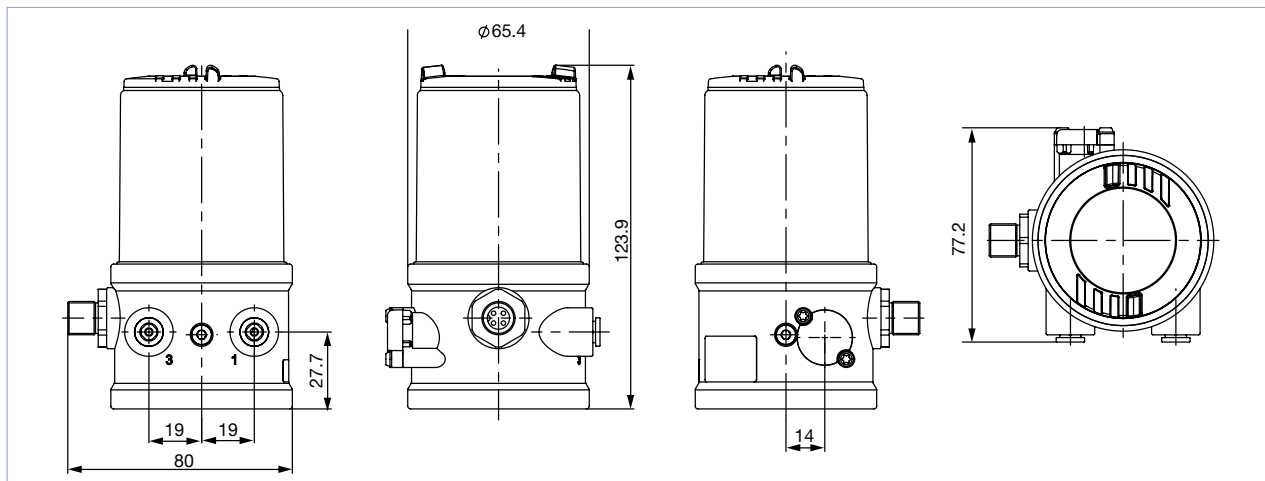

4. Device/Process connections

4.1. Electrical connections

Without fieldbus communication 24 V DC

M12 circular plug, 8-pin																												
	<table border="1"> <thead> <tr> <th>Pin</th> <th>Description</th> <th>Pin assignment</th> </tr> </thead> <tbody> <tr> <td>1</td> <td>Limit switches 1</td> <td>IN 1 / TOP</td> </tr> <tr> <td>2</td> <td>Limit switches 2</td> <td>IN 2 / BOTTOM</td> </tr> <tr> <td>3</td> <td>Operating voltage</td> <td>GND</td> </tr> <tr> <td>4</td> <td>Operating voltage +</td> <td>24 V DC</td> </tr> <tr> <td>5</td> <td>Valve control +</td> <td>Valve +</td> </tr> <tr> <td>6</td> <td>Valve control -</td> <td>Valve -</td> </tr> <tr> <td>7</td> <td>-</td> <td>Not assigned</td> </tr> <tr> <td>8</td> <td>-</td> <td>Not assigned</td> </tr> </tbody> </table>	Pin	Description	Pin assignment	1	Limit switches 1	IN 1 / TOP	2	Limit switches 2	IN 2 / BOTTOM	3	Operating voltage	GND	4	Operating voltage +	24 V DC	5	Valve control +	Valve +	6	Valve control -	Valve -	7	-	Not assigned	8	-	Not assigned
	Pin	Description	Pin assignment																									
	1	Limit switches 1	IN 1 / TOP																									
	2	Limit switches 2	IN 2 / BOTTOM																									
	3	Operating voltage	GND																									
	4	Operating voltage +	24 V DC																									
	5	Valve control +	Valve +																									
	6	Valve control -	Valve -																									
7	-	Not assigned																										
8	-	Not assigned																										

AS-Interface connection

M12 circular plug, 4-pin																
	<table border="1"> <thead> <tr> <th>Pin</th> <th>Description</th> <th>Pin assignment</th> </tr> </thead> <tbody> <tr> <td>1</td> <td>Bus +</td> <td>Bus cable AS-Interface +</td> </tr> <tr> <td>2</td> <td>NC</td> <td>Not assigned</td> </tr> <tr> <td>3</td> <td>Bus -</td> <td>Bus cable AS-Interface -</td> </tr> <tr> <td>4</td> <td>NC</td> <td>Not assigned</td> </tr> </tbody> </table>	Pin	Description	Pin assignment	1	Bus +	Bus cable AS-Interface +	2	NC	Not assigned	3	Bus -	Bus cable AS-Interface -	4	NC	Not assigned
	Pin	Description	Pin assignment													
	1	Bus +	Bus cable AS-Interface +													
	2	NC	Not assigned													
3	Bus -	Bus cable AS-Interface -														
4	NC	Not assigned														

IO-Link connection

M12 circular plug, 5-pin, Port Class A																								
	<table border="1"> <thead> <tr> <th>Pin</th> <th>Description</th> <th>Pin assignment</th> </tr> </thead> <tbody> <tr> <td>1</td> <td>L +</td> <td>24 V DC</td> <td>System supply</td> </tr> <tr> <td>2</td> <td>P24</td> <td>24 V DC</td> <td>Not connected</td> </tr> <tr> <td>3</td> <td>L -</td> <td>0 V (GND)</td> <td>System supply</td> </tr> <tr> <td>4</td> <td>C/Q</td> <td>IO-Link</td> <td>Communication</td> </tr> <tr> <td>5</td> <td>M24</td> <td>0 V (GND)</td> <td>Not connected</td> </tr> </tbody> </table>	Pin	Description	Pin assignment	1	L +	24 V DC	System supply	2	P24	24 V DC	Not connected	3	L -	0 V (GND)	System supply	4	C/Q	IO-Link	Communication	5	M24	0 V (GND)	Not connected
	Pin	Description	Pin assignment																					
	1	L +	24 V DC	System supply																				
	2	P24	24 V DC	Not connected																				
	3	L -	0 V (GND)	System supply																				
4	C/Q	IO-Link	Communication																					
5	M24	0 V (GND)	Not connected																					

M12 circular plug, 5-pin, Port Class B																								
	<table border="1"> <thead> <tr> <th>Pin</th> <th>Description</th> <th>Pin assignment</th> </tr> </thead> <tbody> <tr> <td>1</td> <td>L +</td> <td>24 V DC</td> <td>System supply</td> </tr> <tr> <td>2</td> <td>P24</td> <td>24 V DC</td> <td>Actuator supply</td> </tr> <tr> <td>3</td> <td>L -</td> <td>0 V (GND)</td> <td>System supply</td> </tr> <tr> <td>4</td> <td>Q/C</td> <td>IO-Link</td> <td>-</td> </tr> <tr> <td>5</td> <td>M24</td> <td>0 V (GND)</td> <td>Actuator supply</td> </tr> </tbody> </table>	Pin	Description	Pin assignment	1	L +	24 V DC	System supply	2	P24	24 V DC	Actuator supply	3	L -	0 V (GND)	System supply	4	Q/C	IO-Link	-	5	M24	0 V (GND)	Actuator supply
	Pin	Description	Pin assignment																					
	1	L +	24 V DC	System supply																				
	2	P24	24 V DC	Actuator supply																				
	3	L -	0 V (GND)	System supply																				
4	Q/C	IO-Link	-																					
5	M24	0 V (GND)	Actuator supply																					

DTS 1000110880 EN Version: V Status: RL (released | freigegeben | valide) printed: 13.03.2023

Bürkert system bus (būS) connection

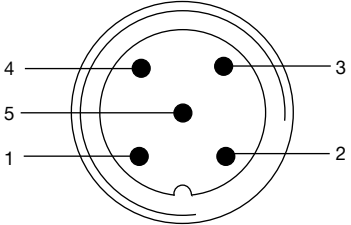
M12 circular plug, 5-pin																			
	<table border="1"><thead><tr><th>Pin</th><th>Description</th><th>Cable colour</th></tr></thead><tbody><tr><td>1</td><td>CAN Shield/Shielding</td><td>CAN Shield/Shielding</td></tr><tr><td>2</td><td>+24 V DC $\pm 25\%$, max. residual ripple 10 %</td><td>Red</td></tr><tr><td>3</td><td>GND / CAN_GND</td><td>Black</td></tr><tr><td>4</td><td>CAN_H</td><td>White</td></tr><tr><td>5</td><td>CAN_L</td><td>Blue</td></tr></tbody></table>	Pin	Description	Cable colour	1	CAN Shield/Shielding	CAN Shield/Shielding	2	+24 V DC $\pm 25\%$, max. residual ripple 10 %	Red	3	GND / CAN_GND	Black	4	CAN_H	White	5	CAN_L	Blue
	Pin	Description	Cable colour																
	1	CAN Shield/Shielding	CAN Shield/Shielding																
	2	+24 V DC $\pm 25\%$, max. residual ripple 10 %	Red																
	3	GND / CAN_GND	Black																
4	CAN_H	White																	
5	CAN_L	Blue																	

5. Product installation

5.1. Combination options with pneumatic process valves

Note:

A decentralized, automated valve system consists of **Control head Type 8695** and a **Process valve ELEMENT Type 21xx**, actuator size 50 mm.

The following information is required to select a complete system:

- **Article no.** of the desired control head **Type 8695**
- **Article no.** of the desired process valve **Type 21xx** (see separate data sheets, **Type 2100 ▶**, **Type 2101 ▶**, **Type 2103 ▶**)

You order two components and receive a complete assembled and certified valve.

Example for decentralised automation of On/Off ELEMENT valve systems

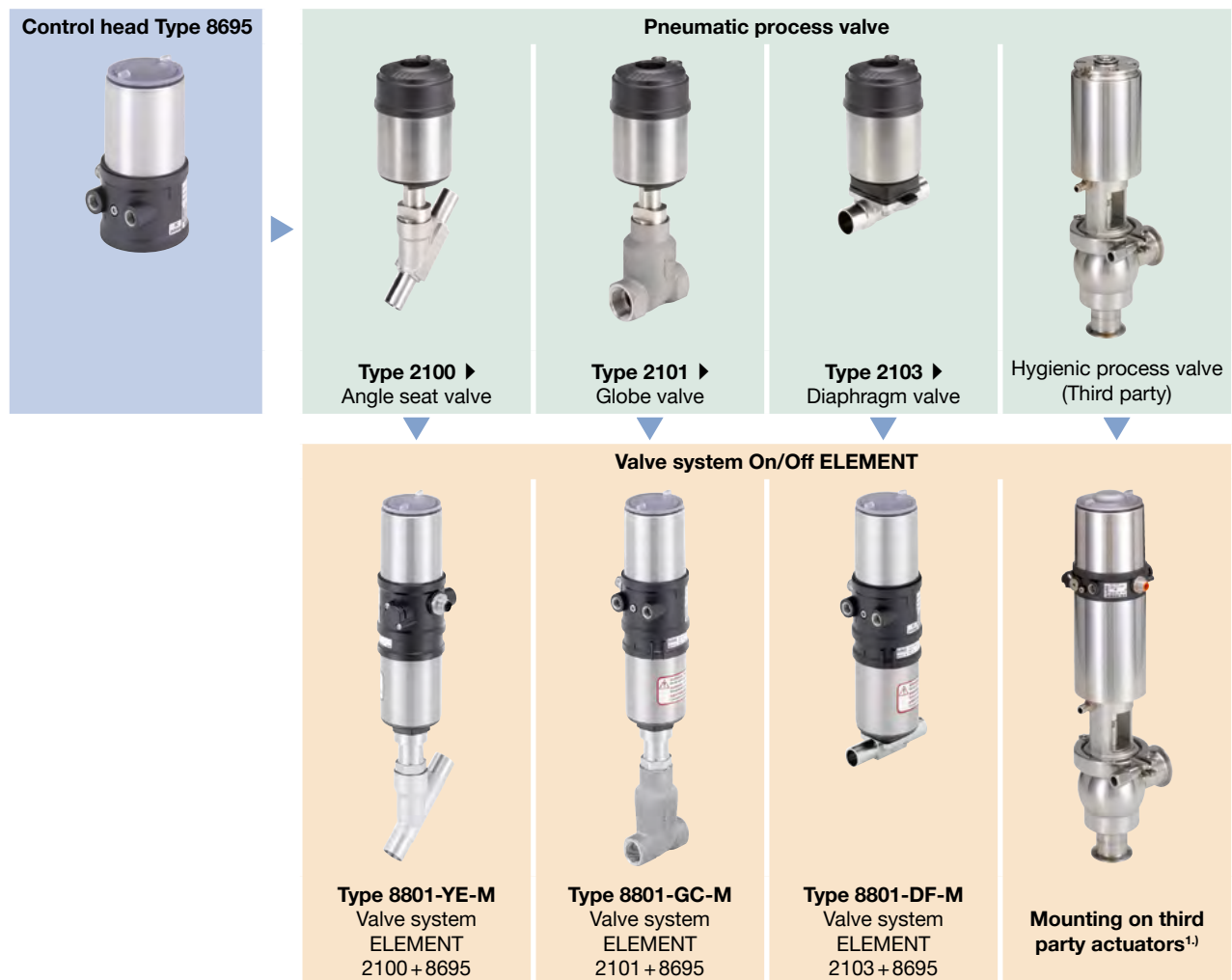

1.) See data sheet **adaptations for third-party drives, KK01 ▶** or contact the appropriate Bürkert sales office.

DTS 1000110880 EN Version: V Status: RL (released | freigegeben | valide) printed: 13.03.2023

6. Ordering information

6.1. Bürkert eShop – Easy ordering and quick delivery



Bürkert eShop – Easy ordering and fast delivery

You want to find your desired Bürkert product or spare part quickly and order directly? Our online shop is available for you 24/7. Sign up and enjoy all the benefits.

[Order online now](#)

6.2. Bürkert product filter

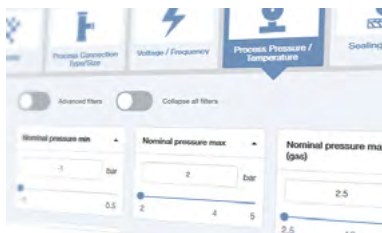

Bürkert product filter – Get quickly to the right product

You want to select products comfortably based on your technical requirements? Use the Bürkert product filter and find suitable articles for your application quickly and easily.

[Try out our product filter](#)

6.3. Ordering chart

Control head for decentralized automation of ELEMENT On/Off process valves Type 21xx

Note:











- Adapter kits must be ordered separately - see [“Adapter kits” on page 11](#).
- All standard versions are UL approved.
- ATEX/IECEX for IO-Link and büS is in preparation.
- Feedback version of IO-Link is in preparation.
- Other versions are available on request.

Electrical Connection	Communication	Control function pilot valve system	Pilot air ports threaded connection	Article no.	
				Standard	ATEX II Cat. 3G/D, IECEx, CCC ^{1.)}
M12 plug connector	IO-Link Port Class A	Einfachwirkend	G 1/8	20032480	20032484
		Doppeltwirkend	G 1/8	20032478	20032482
		ohne	G 1/8	20036715	In Vorbereitung
	IO-Link Port Class B	Einfachwirkend	G 1/8	20036719	In Vorbereitung
		Doppeltwirkend	G 1/8	20036717	In Vorbereitung
		ohne	G 1/8	20036709	In Vorbereitung
	büS	Einfachwirkend	G 1/8	20036713	In Vorbereitung
		Doppeltwirkend	G 1/8	20036711	In Vorbereitung
		ohne	G 1/8	20036709	In Vorbereitung
	AS-Interface S-B.A.E	Single-acting	G 1/8	227444	265075
		Double-acting	G 1/8	227440	265069
	Without fieldbus communication	Single-acting	G 1/8	227446	265077
Double-acting		G 1/8	227442	265071	
Without		G 1/8	234246	265067	

1.) CCC (China Compulsory Certificate) for device versions with Ex approval.

6.4. Ordering chart Accessories

Standard accessories

Description	Article no.
M12 socket, 8-pin with 5 m cable for input and output signals	919267 
Silencer G 1/8	780779 
Silencer, push-in connector	902662 
USB bÜS interface set (bÜS stick + connecting cable with M12 connector + connecting cable M12 to micro USB for bÜS service interface) for connecting to the PC tool Bürkert Communicator	772551 
bÜS cable extension M12, length 1 m	772404 
bÜS cable extension M12, length 3 m	772405 
bÜS cable extension M12, length 5 m	772406 
bÜS cable extension M12, length 10 m	772407 
Sensor puck (spare part)	677245 
Software Bürkert Communicator	LINK 

Adapter kits

Adapter kits for third-party actuators can be found in the data sheet **Adaptation for third-party actuators, KK01**  or contact the appropriate Bürkert sales office.

Description	Actuator size	Control function	Article no.
Adapter kit ELEMENT Types 21xx	Ø 50 mm	Universal	679918 

Bürkert – Close to You

For up-to-date addresses
please visit us at
www.burkert.com

DTS 1000110880 EN Version: V Status: RL (released | freigegeben | validé) printed: 13.03.2023

Austria
Belgium
Czech Republic
Denmark
Finland
France
Germany
Italy
Netherlands

Norway
Poland
Spain
Sweden
Switzerland
Turkey
United Kingdom

