



Instruction Manual

Bypass Blowdown Steam Trap (Free Float Steam Trap with X-element) **J3S-X-RV**

Copyright © 2021 by TLV CO., LTD.

All rights reserved

Contents

| | |
|---|----|
| Introduction | 1 |
| Safety Considerations | 2 |
| Checking the Piping | 4 |
| Operation | 5 |
| Specifications | 6 |
| Configuration | 6 |
| Installation | 8 |
| Maintenance..... | 9 |
| Operating Instructions for Regulation Valve..... | 10 |
| Disassembly/Reassembly | 12 |
| Instructions for Plug/Holder Disassembly and Reassembly ... | 15 |
| Troubleshooting | 16 |
| TLV EXPRESS LIMITED WARRANTY..... | 17 |
| Service | 19 |
| Options..... | 20 |

Introduction

Thank you for purchasing the TLV bypass blowdown steam trap (free float steam trap with X-element).

This product has been thoroughly inspected before being shipped from the factory. When the product is delivered, before doing anything else, check the specifications and external appearance to make sure nothing is out of the ordinary. Also be sure to read this manual carefully before use and follow the instructions to be sure of using the product properly.

This free float steam trap is of a revolutionary design that employs a high-performance X-element as an air vent. It is best suited for steam equipment use. The X-element is very sensitive to changes in temperature, and responds with great accuracy, allowing for the quick discharge of large quantities of initial air and cold condensate immediately after operation start-up, reducing start-up times. It also reacts with great sensitivity to the inflow of large quantities of condensate and hot air during operation, preventing air binding.

This steam trap, which combines the superior features of the X-element with the proven performance record of the free float, increases heating efficiency and reduces manpower requirements for maintenance and bypass blowdown.

The regulation valve incorporated into the cover makes bypass blow possible. In addition to discharging condensate and air produced on startup through the orifice and air vent valve, the regulation valve can be employed to increase condensate and air discharge for more rapid start-up. Also by adjusting the aperture of the regulation valve, it can be used to force steam discharge in order to solve problems with condensate drainage on cylinder dryers or equipment prone to condensate backup due to steam locking phenomenon.







If detailed instructions for special order specifications or options not contained in this manual are required, please contact TLV for full details.

This instruction manual is intended for use with the model(s) listed on the front cover. It is necessary not only for installation but for subsequent maintenance, disassembly/reassembly and troubleshooting. Please keep it in a safe place for future reference.

Safety Considerations

- Read this section carefully before use and be sure to follow the instructions.
- Installation, inspection, maintenance, repairs, disassembly, adjustment and valve opening/closing should be carried out only by trained maintenance personnel.
- The precautions listed in this manual are designed to ensure safety and prevent equipment damage and personal injury. For situations that may occur as a result of erroneous handling, three different types of cautionary items are used to indicate the degree of urgency and the scale of potential damage and danger: DANGER, WARNING and CAUTION.
- The three types of cautionary items above are very important for safety: be sure to observe all of them as they relate to installation, use, maintenance, and repair. Furthermore, TLV accepts no responsibility for any accidents or damage occurring as a result of failure to observe these precautions.

Symbols

| | |
|---|--|
|  | Indicates a DANGER, WARNING or CAUTION item. |
|  | Indicates an urgent situation which poses a threat of death or serious injury |
|  | Indicates that there is a potential threat of death or serious injury |
|  | Indicates that there is a possibility of injury or equipment / product damage |
|  | NEVER apply direct heat to the float. The float may explode due to increased internal pressure, causing accidents leading to serious injury or damage to property and equipment. |
|  | Install properly and DO NOT use this product outside the recommended operating pressure, temperature and other specification ranges. Improper use may result in such hazards as damage to the product or malfunctions that may lead to serious accidents. Local regulations may restrict the use of this product to below the conditions quoted. |
| | DO NOT use this product in excess of the maximum operating pressure differential. Such use could make discharge impossible (blocked). |
| | Take measures to prevent people from coming into direct contact with product outlets. Failure to do so may result in burns or other injury from the discharge of fluids. |

Continued on the next page

| | |
|--|---|
|  CAUTION | <p>Use gloves when operating the regulation valve and keep all body parts well clear of the product.</p> <p>Failure to do so could result in burns, other injury or damage from the blowing of small amounts of steam and condensate.</p> |
| | <p>When disassembling or removing the product, wait until the internal pressure equals atmospheric pressure and the surface of the product has cooled to room temperature.</p> <p>Disassembling or removing the product when it is hot or under pressure may lead to discharge of fluids, causing burns, other injuries or damage.</p> |
| | <p>Be sure to use only the recommended components when repairing the product, and NEVER attempt to modify the product in any way.</p> <p>Failure to observe these precautions may result in damage to the product and burns or other injury due to malfunction or the discharge of fluids.</p> |
| | <p>Use only under conditions in which no freeze-up will occur.</p> <p>Freezing may damage the product, leading to fluid discharge, which may cause burns or other injury.</p> |
| | <p>Use only under conditions in which no water hammer will occur.</p> <p>The impact of water hammer may damage the product, leading to fluid discharge, which may cause burns or other injury.</p> |

Checking the Piping



Use only under conditions in which no water hammer will occur. The impact of water hammer may damage the product, leading to fluid discharge, which may cause burns or other injury.

Check to make sure that the pipes to be connected to the product have been installed properly.

1. Is the pipe diameter suitable?
2. Is the piping where the product is to be installed horizontal?
3. Has sufficient space been secured for maintenance?
4. Have maintenance valves been installed at the inlet and outlet? If the outlet is subject to back pressure, has a check valve (TLV-CK) been installed?
5. Is the inlet pipe as short as possible, with as few bends as possible, and installed so the liquid will flow naturally down into the product?
6. Has the piping work been done correctly, as shown in the figures below?

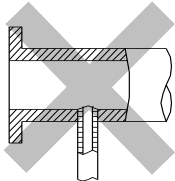
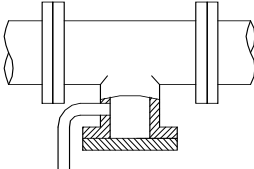
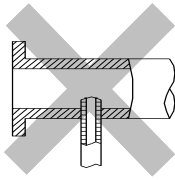
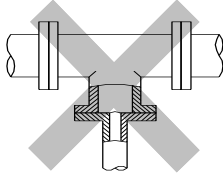
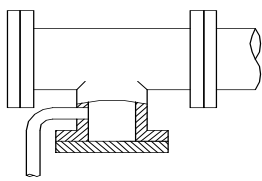
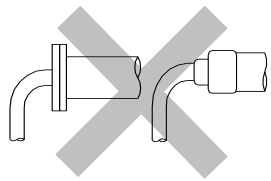
| Requirement | Correct | Incorrect |
|--|---|--|
| Install catchpot with the proper diameter. | |  <p>Diameter is too small.</p> |
| Make sure the flow of condensate is not obstructed. |  |  <p>Diameter is too small and inlet protrudes into pipe interior.</p> |
| To prevent rust and scale from flowing into the trap, the inlet pipe should be connected 25 to 50 mm (1 to 2 in) above the base of the T-pipe. | |  <p>Rust and scale flow into the trap with the condensate.</p> |
| When installing on the blind end, make sure the flow of condensate is not obstructed. |  |  <p>Condensate collects in the pipe.</p> |

Operation

Principles of air and condensate discharge:

1. Initial Air and Cold Condensate Discharge

At startup, before steam is supplied, the trap is cold so the X-element is contracted and the air vent valve seat (A) is open. This allows for the rapid discharge of air through the air vent valve (A) and cold condensate through the orifice (B), when steam is first supplied to the system. Initial air/condensate can be discharged rapidly using the regulation valve as necessary.

Regulation valve: open

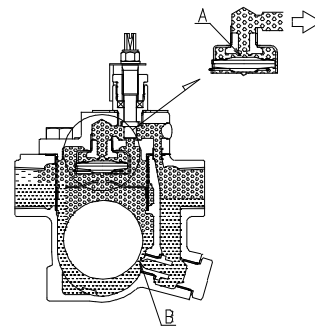

2. Condensate Discharge

After the discharge of initial air and cold condensate (regulation valve closed), the heat of the inflowing steam and condensate causes the X-element to expand, closing the air vent valve (A). The rising condensate level causes the float to rise due to buoyancy, opening the orifice (B) and allowing condensate to be discharged.

Regulation valve: closed

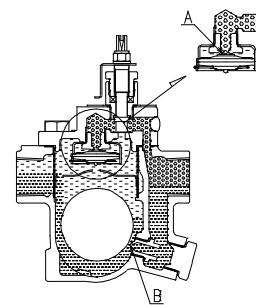

3. Hot Air Discharge

Should hot air flow into the trap with the steam during normal operation, the temperature of the X-element drops, causing it to momentarily contract and open the air vent valve (A), which allows for the rapid discharge of the air. After the air is discharged and steam contacts the X-element, the temperature will increase causing the air vent valve (A) to close.

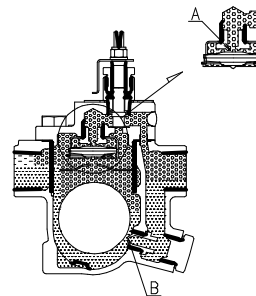

4. Closed Position

When the condensate flow rate decreases, the float falls as condensate is discharged, closing off the orifice (B). A water seal is maintained at all times over the orifice (B) to prevent steam loss. NOTE: The high steam temperature causes the X-element to expand, keeping the air vent closed.

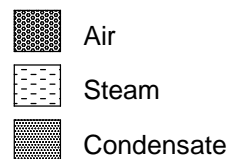
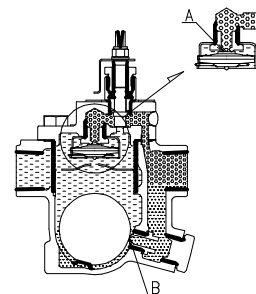

Specifications



Install properly and **DO NOT** use this product outside the recommended operating pressure, temperature and other specification ranges. Improper use may result in such hazards as damage to the product or malfunctions which may lead to serious accidents. Local regulations may restrict the use of this product to below the conditions quoted.



DO NOT use this product in excess of the maximum operating pressure differential; such use could make discharge impossible (blocked).



Use only under conditions in which no freeze-up will occur. Freezing may damage the product, leading to fluid discharge, which may cause burns or other injury.

Refer to the product nameplate for detailed specifications.

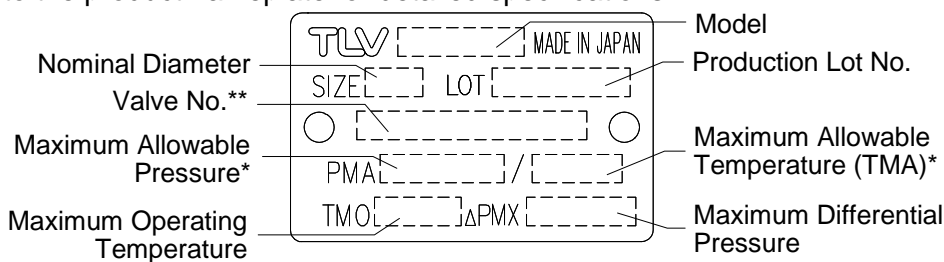

* Maximum allowable pressure (PMA) and maximum allowable temperature (TMA) are PRESSURE SHELL DESIGN CONDITIONS, **NOT** OPERATING CONDITIONS.

** Valve No. is displayed for products with options. This item is omitted from the nameplate when there are no options.

Configuration

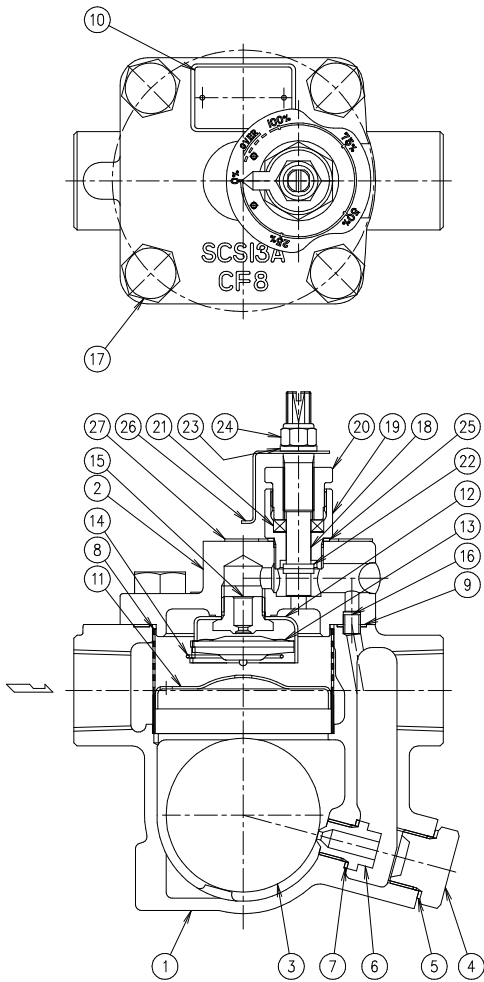

| No. | Name | M* | R* | F* | V* |
|-----|---------------------------|----|----|----|----|
| 1 | Body | | | | |
| 2 | Cover | | | | |
| 3 | Float | | | ✓ | |
| 4 | Orifice Plug | | | | |
| 5 | Orifice Plug Gasket | ✓ | ✓ | | |
| 6 | Orifice | | ✓ | | |
| 7 | Orifice Gasket | ✓ | ✓ | | |
| 8 | Screen | | ✓ | | |
| 9 | Cover Gasket | ✓ | ✓ | | |
| 10 | Nameplate | | | | |
| 11 | Float Cover | | ✓ | | |
| 12 | X-element Guide | | ✓ | | |
| 13 | X-element | | ✓ | | |
| 14 | Spring Clip | | ✓ | | |
| 15 | Air Vent Valve Seat | | ✓ | | |
| 16 | Connector | | | | |
| 17 | Cover Bolt | | | | |
| 18 | Regulation Valve | | | | ✓ |
| 19 | Gland Case | | | | ✓ |
| 20 | Gland Retainer Nut | | | | ✓ |
| 21 | Gland Packing | | | | ✓ |
| 22 | Pin | | | | ✓ |
| 23 | Washer | | | | ✓ |
| 24 | Locknut | | | | ✓ |
| 25 | Gland Case Gasket | ✓ | ✓ | | ✓ |
| 26 | Aperture Indicator | | | | ✓ |
| 27 | Aperture Indication Plate | | | | |

* Replacement parts are available only in the following kits:
M = Maintenance Kit R = Repair Kit
F = Float V = Regulation Valve Unit

Installation



Install properly and **DO NOT** use this product outside the recommended operating pressure, temperature and other specification ranges. Improper use may result in such hazards as damage to the product or malfunctions which may lead to serious accidents. Local regulations may restrict the use of this product to below the conditions quoted.



Take measures to prevent people from coming into direct contact with product outlets. Failure to do so may result in burns or other injury from the discharge of fluids.

Installation, inspection, maintenance, repairs, disassembly, adjustment and valve opening/closing should be carried out only by trained maintenance personnel.

1. Before installation, be sure to remove all protective seals.
 2. Before installing the product, open the inlet valve and blow out the piping to remove any piping scraps, dirt and oil. Close the inlet valve after blowdown.
 3. Install the product so the arrow on the body is pointing in the direction of flow.
 4. The product should be inclined no more than 5° horizontally and front-to-back.
 5. Install a condensate outlet valve and outlet piping.
 6. Open the inlet and outlet valves and ensure that the product functions properly.
- If there is a problem, determine the cause using the “Troubleshooting” section in this manual.

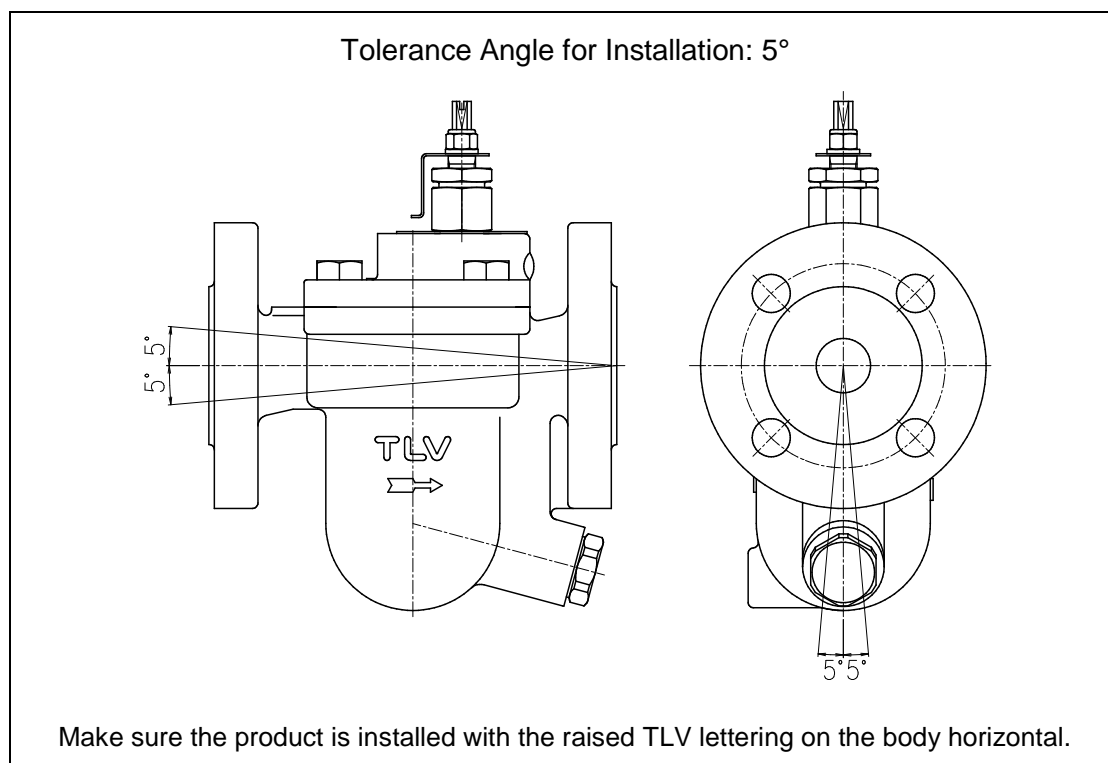

Maintenance



Take measures to prevent people from coming into direct contact with product outlets. Failure to do so may result in burns or other injury from the discharge of fluids.

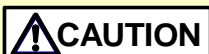

Be sure to use only the recommended components when repairing the product, and NEVER attempt to modify the product in any way. Failure to observe these precautions may result in damage to the product or burns or other injury due to malfunction or the discharge of fluids.

Operational Check

Before carrying out a visual inspection, make sure that the regulation valve is closed. A visual inspection of the following items should be done on a daily basis to determine whether the product is operating properly or has failed. Periodically (at least biannually) the operation should also be checked by using diagnostic equipment, such as a stethoscope, thermometer, TLV Pocket TrapMan or TLV TrapMan.

To confirm that the regulation valve is closed, make sure that the aperture indicator for the regulation valve points to “0%” on the aperture indication plate. If the valve cannot be fully closed, there is a problem. Refer to the “Troubleshooting” section to locate and remedy the cause.

If the product or the regulation valve should fail, it may cause damage to piping and equipment, resulting in faulty or low quality products or losses due to steam leakage.

| | |
|------------------------------------|---|
| Normal: | Condensate is discharged continuously, together with flash steam, and the sound of flow can be heard. If there is very little condensate, there is almost no sound of flow. |
| Blocked: (Discharge Impossible) | No condensate is discharged. The product is quiet and makes no noise, and the surface temperature of the product is low. |
| Blowing: | Live steam continually flows from the outlet and there is a continuous metallic sound. |
| Steam Leakage: | Live steam is discharged through the product outlet together with condensate, accompanied by a high-pitched sound. |

(When conducting a visual inspection, flash steam is sometimes mistaken for steam leakage. For this reason, the use of a steam trap diagnostic instrument – such as TLV TrapMan – in conjunction with the visual inspection is highly recommended.)



Parts Inspection

When parts have been removed, or during periodic inspections, use the following table to inspect the parts and replace any that are found to be defective.

| Procedure |
|--|
| Gaskets: Check for warping or scratches |
| Screen: Check for clogging or corrosion |
| X-element, Air Vent Valve Seat: Check for scratches |
| Float: Check for scratches or dents |
| Regulation Valve: Check for scratches on the surface |
| Body Interior: Check for build-up |
| Orifice Opening: Check for dirt, oil film, wear or scratches |

Operating Instructions for Regulation Valve



Use gloves when operating the regulation valve and keep all body parts well clear of the product. Failure to do so could result in burns, other injury or damage from the blowing of small amounts of steam and condensate.

Regulation Valve Unit

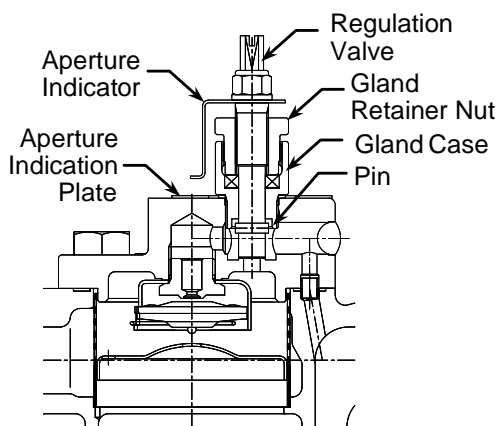

Steam Discharge Capacity Graph

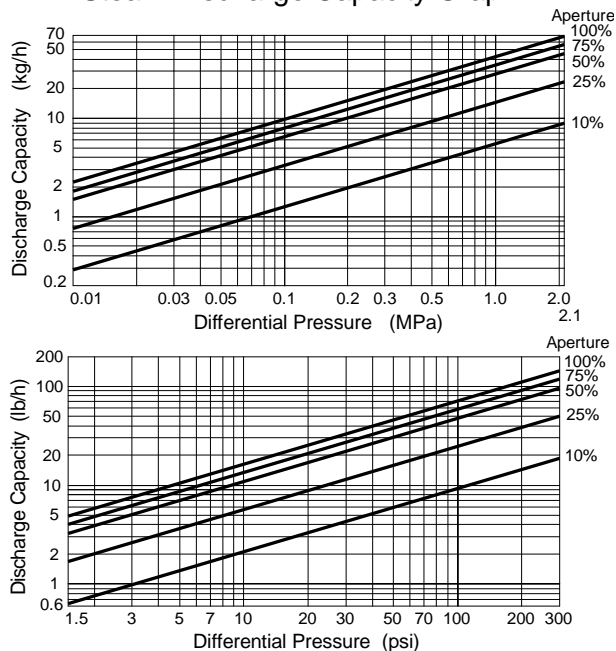

Operating Procedure

- When the product is shipped from the factory, the regulation valve is positioned in the lowest, valve-closed position.
- Tools required (the regulation valve can be operated with any of the tools listed below):
 - Spanner (7 mm ($\frac{9}{32}$ in) across flats), adjustable wrench, flat-head screwdriver, handle (optional)
- The following operating instruction is for the case that a spanner is used.
- When operating the regulation valve, make sure to hold the hexagonal part of the gland case in place. (Use a part of the hexagonal section that does not touch the aperture indicator.)
 - When using the regulation valve for the bypass blowdown function (to shorten initial start-up time, etc.):
 - Use in a fully-opened position (aperture: 100%) at normal operation, then back to fully-closed position (aperture: 0%) once blowdown is complete.
 - When using the regulation valve to eliminate steam locking, etc.:
 - Reference the Steam Discharge Capacity graph and the percent open marking on the aperture indication plate to adjust the amount of steam blow.

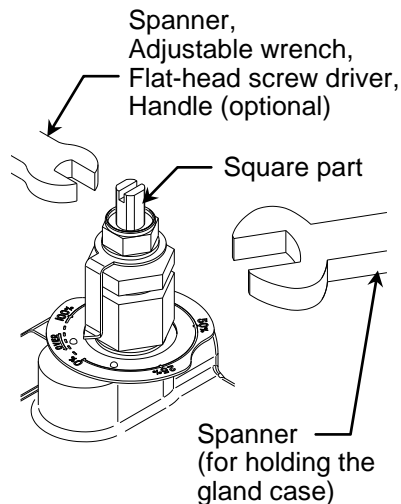

NOTE: When operating the regulation valve, make sure to use tools specified in step 2. Use the same tool for opening/closing the valve, as much as possible. If the valve is opened/closed with a spanner, adjustable wrench or a handle, it may be difficult to operate it with a flat-head screwdriver afterwards (as these tools are capable of tightening to a much higher

degree). In that case, use a spanner, adjustable wrench or handle. Do not turn the locknut, gland retainer nut, gland case, etc. while adjusting the regulation valve. Failure to do so could result in burns, other injury or damage from the blowing of small amounts of steam and condensate.

For opening the valve:

- Fit a spanner onto the the square part of the top of the regulation valve and turn slowly in the counterclockwise direction.

NOTE: Do not turn the regulation valve past the point at which it stops (where the internal pin contacts the gland case)

- The steam quantity can be adjusted by using the Steam Discharge Capacity Graph to find out what valve aperture corresponds to your desired steam discharge quantity and differential pressure, then using the valve aperture indication plate to set the valve aperture to the value taken from the graph.

For closing the valve:

- Fit a spanner onto the the square part of the very top of the regulation valve and turn slowly in the clockwise direction.
5. If steam should leak from the gland retainer nut or gland case, it can be stopped by further tightening the gland retainer nut. (Turn the regulation valve as far closed as it will go.)

Disassembly/Reassembly



NEVER apply direct heat to the float. The float may explode due to increased internal pressure, causing accidents leading to serious injury or damage to property and equipment.



When disassembling or removing the product, wait until the internal pressure equals atmospheric pressure and the surface of the product has cooled to room temperature. Disassembling or removing the product when it is hot or under pressure may lead to discharge of fluids, causing burns, other injuries or damage.

Use the following procedures to remove components. Use the same procedures in reverse to reassemble.

(Installation, inspection, maintenance, repairs, disassembly, adjustment and valve opening/closing should be carried out only by trained maintenance personnel.)

Drain Plug (Option)

| Part | During Disassembly | During Reassembly |
|-------------------|--|--|
| Drain Plug | Remove with a socket wrench | Consult the table of tightening torques and tighten to the proper torque |
| Drain Plug Gasket | Remove the gasket and clean sealing surfaces | Replace with a new gasket; coat surfaces with anti-seize |

Detaching/Reattaching the Cover

| Part | During Disassembly | During Reassembly |
|--------------|--|--|
| Cover Bolt | Remove with a socket wrench | Consult the table of tightening torques and tighten to the proper torque |
| Cover | Remove by lifting up and off | Make sure there are no pieces of the old gasket left on the sealing surfaces of the body and cover, align the cover with the body and connector and reattach |
| Connector | Remove the connector | Reinsert into the hole in the body |
| Cover Gasket | Remove the gasket and clean sealing surfaces | Replace with a new gasket if misshapen or damaged |

Disassembly/Reassembly of Components Inside the Cover

| Part | During Disassembly | During Reassembly |
|---------------------|--|---|
| Spring Clip | Pinch the insides together and remove from the X-element guide | Insert securely into the groove in the guide |
| X-element | Remove from the X-element guide | Insert after making sure it is in the correct orientation (Figure A) |
| Air Vent Valve Seat | Remove with a socket wrench | Consult the table of tightening torques and tighten to the proper torque |
| X-element Guide | Remove without bending | Fix with the air vent valve seat and make sure the X-element can be inserted smoothly |

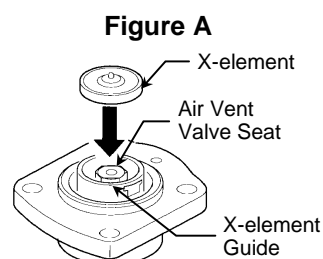

Detaching/Reattaching the Regulation Valve Unit

| Part | During Disassembly | During Reassembly |
|------------------------|--|---|
| Regulation Valve Unit* | Remove with a spanner (use spanner only on Gland Case section) | See "NOTE when assembling the unit" described below; consult the table of tightening torques and tighten to the proper torque |
| Gland Case Gasket | and clean sealing surfaces | Replace with a new gasket; coat surfaces with anti-seize |

*The regulation valve unit cannot be disassembled. It can only be detached/reattached as a unit.

NOTE: When assembling the unit:

When installing the regulation valve unit in the cover, make sure that the zero points of the aperture indicator and the aperture indication plate are aligned. If the zero points do not match up, they must be realigned.

Refer to the following steps for aligning the zero points:

1. Turn the regulation valve of the regulation valve unit counterclockwise and pull it up.
2. Loosen the locknut of the regulation valve.
3. Install the gland case gasket and the regulation valve unit in the cover (refer to the "Table of Tightening Torques").
4. Turn the regulation valve clockwise to close using the appropriate tool.
5. Turn the aperture indicator portion of the regulation valve unit until its point is aligned with the "0%" marking on the aperture indication plate. Once it is aligned with the marking, tighten the locknut.

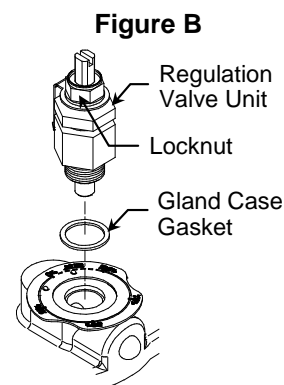

Disassembly/Reassembly of Components Inside the Body

| Part | During Disassembly | During Reassembly |
|----------------------|--|--|
| Float Cover & Screen | Lift straight up and out while rocking slowly | Align the arrows on the float cover/screen and the body, insert with the tab on the bottom fitting into the slot in the body; make sure the screen does not stick out of the body (Figure C) |
| Float | Remove, being careful not to scratch the surface | Insert, being careful not to scratch the surface |
| Orifice Plug | Remove with a socket wrench | Consult the table of tightening torques and tighten to the proper torque |
| Orifice Plug Gasket | Remove the gasket and clean sealing surfaces | Replace with a new gasket; coat surfaces with anti-seize |
| Orifice | Remove with a socket wrench | Consult the table of tightening torques and tighten to the proper torque |
| Orifice Gasket | Remove the gasket and clean sealing surfaces | Replace with a new gasket; coat surfaces with anti-seize |

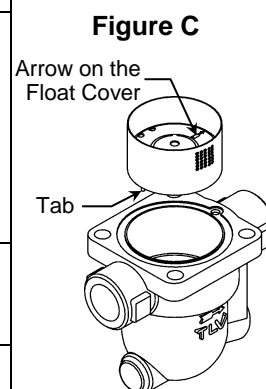

Table of Tightening Torques

| | Torque | | Distance Across Flats | |
|---------------------|--------|----------|-----------------------|-----------------------------------|
| | N·m | (lbf·ft) | mm | (in) |
| Cover Bolt | 50 | (37) | 17 | (²¹ / ₃₂) |
| Air Vent Valve Seat | 35 | (26) | 19 | (³ / ₄) |
| Orifice Plug | 80 | (59) | 24 | (¹⁵ / ₁₆) |
| Orifice | 30 | (22) | 10 | (³ / ₈) |
| Gland Case | 30 | (22) | 22 | (⁷ / ₈) |
| Gland Retainer Nut | 30 | (22) | 22 | (⁷ / ₈) |

(1 N·m ≈ 10 kg·cm)

NOTE: - Coat all threaded portions with anti-seize.
 - If drawings or other special documentation were supplied for the product, any torque given there takes precedence over values shown here.

Exploded View

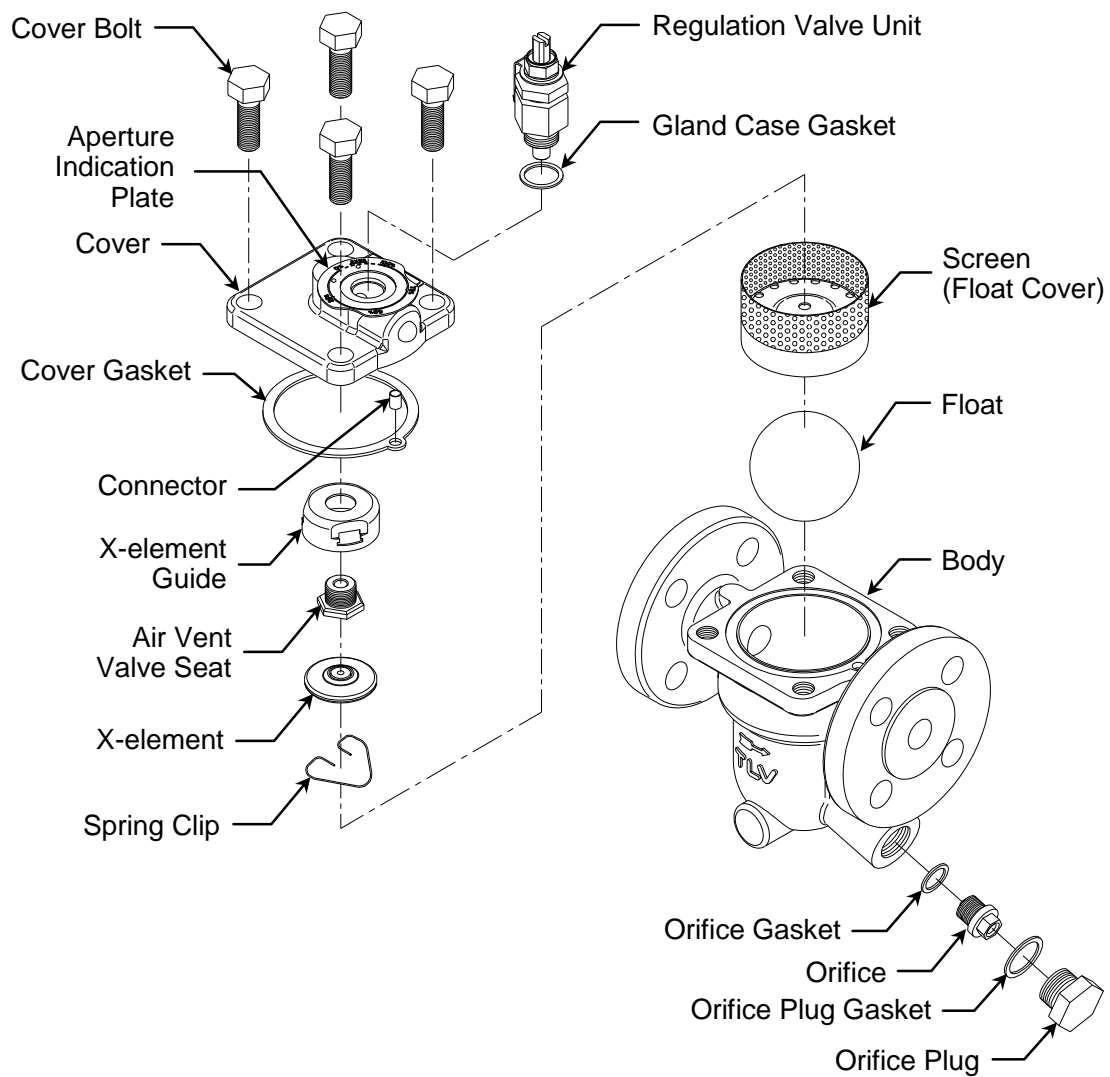

Instructions for Plug/Holder Disassembly and Reassembly

The seal on the threaded plugs/holders found on TLV products is formed by a flat metal gasket. There are various installation orientations for the gaskets, such as horizontal, diagonal and downward, and the gasket may be pinched in the thread recesses during assembly.

Instructions for Disassembly and Reassembly

- ① Remove the plug/holder using a tool of the specified size (distance across flats).
- ② The gasket should not be reused. Be sure to replace it with a new gasket.

- ③ Clean the gasket surfaces of the plug/holder and the product body using a rag and/or cleaning agents, then check to make sure the surfaces are not scratched or deformed.

- ④ Coat both the gasket surface of the plug/holder and the threads of the plug/holder with anti-seize, then press the gasket onto the center of the gasket surface of the plug/holder, making sure the anti-seize affixes the gasket tightly to the plug/holder. Check to make sure the gasket is not caught in the recesses of the threads.

- ⑤ Hold the plug/holder upside down to make sure that the anti-seize makes the gasket stick to the plug/holder even when the plug/holder is held upside down.

- ⑥ Screw the plug/holder by hand into the product body while making sure that the gasket remains tightly affixed to the center of the gasket surface of the plug/holder. Make sure the entire gasket is making contact with the gasket surface of the product body. It is important at this point to make sure the gasket is not pinched in the thread recesses of the plug/holder.

- ⑦ Tighten the plug/holder to the proper torque.

- ⑧ Next, begin the supply of steam and check to make sure there is no leakage from the part just tightened. If there is leakage, immediately close the inlet valve and, if there is a bypass valve, take the necessary steps to release any residual pressure. After the surface of the product cools to room temperature, repeat the procedure beginning from step ①.

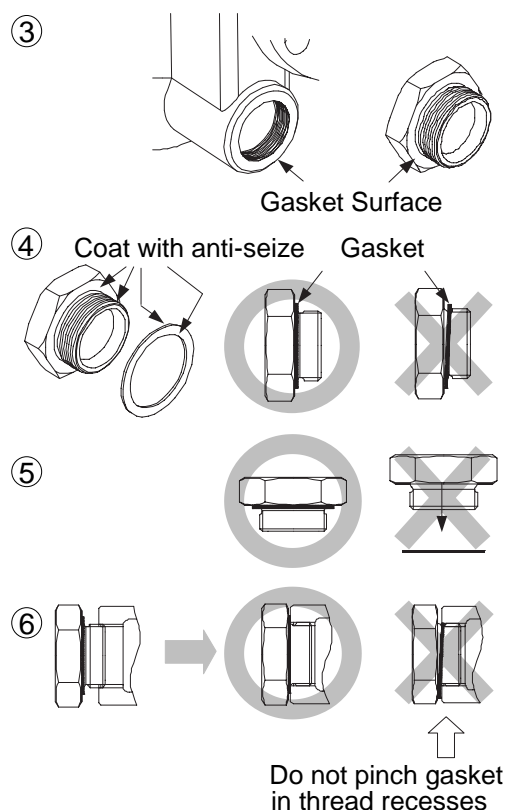

Troubleshooting



NEVER apply direct heat to the float. The float may explode due to increased internal pressure, causing accidents leading to serious injury or damage to property and equipment.



When disassembling or removing the product, wait until the internal pressure equals atmospheric pressure and the surface of the product has cooled to room temperature. Disassembling or removing the product when it is hot or under pressure may lead to discharge of fluids, causing burns, other injuries or damage.

If the product fails to operate properly, use the following table to locate the cause and remedy.

| Problem | Cause | Remedy |
|--|--|--|
| No condensate is discharged (blocked) or discharge is poor | The float is damaged or filled with condensate | Replace with a new float |
| | The orifice opening, screen or piping are clogged with rust and scale | Clean parts |
| | The X-element is scratched or damaged | Replace with a new X-element |
| | The product operating pressure exceeds the maximum specified pressure, or there is insufficient pressure differential between the product inlet and outlet | Compare specifications and actual operating conditions |
| | Steam locking has occurred | Perform a bypass blowdown or close the trap inlet valve and allow the trap to cool |
| Steam is discharged or leaks from the outlet (blowing) (steam leakage) | Clogged orifice opening or regulation valve opening, or rust and scale build-up beneath the float | Clean parts |
| | Scratches on the orifice | Replace with a new orifice |
| | The float is misshapen or has surface build-up | Clean or replace with a new float |
| | Improper installation orientation | Correct the installation |
| | Trap vibration | Lengthen the inlet piping and fasten it securely |
| | The regulation valve is opened | Close the regulation valve |
| Steam is blowing from the gland of the regulation valve | The gland retainer nut is loose | Re-tighten the gland retainer nut or replace with a new regulation valve unit |
| | The regulation valve does not move | Clean parts or replace with a new regulation valve unit |
| Steam is leaking from a place other than the outlet | Gasket deterioration or damage | Replace with new gasket(s) |
| | Improper tightening torques were used | Tighten to the proper torque |
| Float frequently becomes damaged | Water hammer has occurred | Study and correct the piping |

NOTE: When replacing parts with new, use the parts list for reference, and replace with parts from the Maintenance kit, Repair kit, etc. Please note that replacement parts are only available as part of a replacement parts kit.

TLV EXPRESS LIMITED WARRANTY

Subject to the limitations set forth below, TLV CO., LTD., a Japanese corporation (“**TLV**”), warrants that products which are sold by it, TLV International Inc. (“**TII**”) or one of its group companies excluding TLV Corporation (a corporation of the United States of America), (hereinafter the “**Products**”) are designed and manufactured by TLV, conform to the specifications published by TLV for the corresponding part numbers (the “**Specifications**”) and are free from defective workmanship and materials. The party from whom the Products were purchased shall be known hereinafter as the “**Seller**”. With regard to products or components manufactured by unrelated third parties (the “**Components**”), TLV provides no warranty other than the warranty from the third party manufacturer(s), if any.

Exceptions to Warranty

This warranty does not cover defects or failures caused by:

1. improper shipping, installation, use, handling, etc., by persons other than TLV, TII or TLV group company personnel, or service representatives authorized by TLV; or
2. dirt, scale or rust, etc.; or
3. improper disassembly and reassembly, or inadequate inspection and maintenance by persons other than TLV or TLV group company personnel, or service representatives authorized by TLV; or
4. disasters or forces of nature or Acts of God; or
5. abuse, abnormal use, accidents or any other cause beyond the control of TLV, TII or TLV group companies; or
6. improper storage, maintenance or repair; or
7. operation of the Products not in accordance with instructions issued with the Products or with accepted industry practices; or
8. use for a purpose or in a manner for which the Products were not intended; or
9. use of the Products in a manner inconsistent with the Specifications; or
10. use of the Products with Hazardous Fluids (fluids other than steam, air, water, nitrogen, carbon dioxide and inert gases (helium, neon, argon, krypton, xenon and radon)); or
11. failure to follow the instructions contained in the TLV Instruction Manual for the Product.

Duration of Warranty

This warranty is effective for a period of one (1) year after delivery of Products to the first end user. Notwithstanding the foregoing, asserting a claim under this warranty must be brought within three (3) years after the date of delivery to the initial buyer if not sold initially to the first end user.

ANY IMPLIED WARRANTIES NOT NEGATED HEREBY WHICH MAY ARISE BY OPERATION OF LAW, INCLUDING THE IMPLIED WARRANTIES OF MERCHANTABILITY AND FITNESS FOR A PARTICULAR PURPOSE AND ANY EXPRESS WARRANTIES NOT NEGATED HEREBY, ARE GIVEN SOLELY TO THE INITIAL BUYER AND ARE LIMITED IN DURATION TO ONE (1) YEAR FROM THE DATE OF SHIPMENT BY THE SELLER.

Exclusive Remedy

THE EXCLUSIVE REMEDY UNDER THIS WARRANTY, UNDER ANY EXPRESS WARRANTY OR UNDER ANY IMPLIED WARRANTIES NOT NEGATED HEREBY (INCLUDING THE IMPLIED WARRANTIES OF MERCHANTABILITY AND FITNESS FOR A PARTICULAR PURPOSE), IS **REPLACEMENT**; PROVIDED: (a) THE CLAIMED DEFECT IS

REPORTED TO THE SELLER IN WRITING WITHIN THE WARRANTY PERIOD, INCLUDING A DETAILED WRITTEN DESCRIPTION OF THE CLAIMED DEFECT AND HOW AND WHEN THE CLAIMED DEFECTIVE PRODUCT WAS USED; AND (b) THE CLAIMED DEFECTIVE PRODUCT AND A COPY OF THE PURCHASE INVOICE IS RETURNED TO THE SELLER, FREIGHT AND TRANSPORTATION COSTS PREPAID, UNDER A RETURN MATERIAL AUTHORIZATION AND TRACKING NUMBER ISSUED BY THE SELLER. ALL LABOR COSTS, SHIPPING COSTS, AND TRANSPORTATION COSTS ASSOCIATED WITH THE RETURN OR REPLACEMENT OF THE CLAIMED DEFECTIVE PRODUCT ARE SOLELY THE RESPONSIBILITY OF BUYER OR THE FIRST END USER. THE SELLER RESERVES THE RIGHT TO INSPECT ON THE FIRST END USER'S SITE ANY PRODUCTS CLAIMED TO BE DEFECTIVE BEFORE ISSUING A RETURN MATERIAL AUTHORIZATION. SHOULD SUCH INSPECTION REVEAL, IN THE SELLER'S REASONABLE DISCRETION, THAT THE CLAIMED DEFECT IS NOT COVERED BY THIS WARRANTY, THE PARTY ASSERTING THIS WARRANTY SHALL PAY THE SELLER FOR THE TIME AND EXPENSES RELATED TO SUCH ON-SITE INSPECTION.

Exclusion of Consequential and Incidental Damages

IT IS SPECIFICALLY ACKNOWLEDGED THAT THIS WARRANTY, ANY OTHER EXPRESS WARRANTY NOT NEGATED HEREBY, AND ANY IMPLIED WARRANTY NOT NEGATED HEREBY, INCLUDING THE IMPLIED WARRANTIES OF MERCHANTABILITY AND FITNESS FOR A PARTICULAR PURPOSE, DO NOT COVER, AND NEITHER TLV, TII NOR ITS TLV GROUP COMPANIES WILL IN ANY EVENT BE LIABLE FOR, INCIDENTAL OR CONSEQUENTIAL DAMAGES, INCLUDING, BUT NOT LIMITED TO LOST PROFITS, THE COST OF DISASSEMBLY AND SHIPMENT OF THE DEFECTIVE PRODUCT, INJURY TO OTHER PROPERTY, DAMAGE TO BUYER'S OR THE FIRST END USER'S PRODUCT, DAMAGE TO BUYER'S OR THE FIRST END USER'S PROCESSES, LOSS OF USE, OR OTHER COMMERCIAL LOSSES. WHERE, DUE TO OPERATION OF LAW, CONSEQUENTIAL AND INCIDENTAL DAMAGES UNDER THIS WARRANTY, UNDER ANY OTHER EXPRESS WARRANTY NOT NEGATED HEREBY OR UNDER ANY IMPLIED WARRANTY NOT NEGATED HEREBY (INCLUDING THE IMPLIED WARRANTIES OF MERCHANTABILITY AND FITNESS FOR A PARTICULAR PURPOSE) CANNOT BE EXCLUDED, SUCH DAMAGES ARE EXPRESSLY LIMITED IN AMOUNT TO THE PURCHASE PRICE OF THE DEFECTIVE PRODUCT. THIS EXCLUSION OF CONSEQUENTIAL AND INCIDENTAL DAMAGES, AND THE PROVISION OF THIS WARRANTY LIMITING REMEDIES HEREUNDER TO REPLACEMENT, ARE INDEPENDENT PROVISIONS, AND ANY DETERMINATION THAT THE LIMITATION OF REMEDIES FAILS OF ITS ESSENTIAL PURPOSE OR ANY OTHER DETERMINATION THAT EITHER OF THE ABOVE REMEDIES IS UNENFORCEABLE, SHALL NOT BE CONSTRUED TO MAKE THE OTHER PROVISIONS UNENFORCEABLE.

Exclusion of Other Warranties

THIS WARRANTY IS IN LIEU OF ALL OTHER WARRANTIES, EXPRESS OR IMPLIED, AND ALL OTHER WARRANTIES, INCLUDING BUT NOT LIMITED TO THE IMPLIED WARRANTIES OF MERCHANTABILITY AND FITNESS FOR A PARTICULAR PURPOSE, ARE EXPRESSLY DISCLAIMED.

Severability

Any provision of this warranty which is invalid, prohibited or unenforceable in any jurisdiction shall, as to such jurisdiction, be ineffective to the extent of such invalidity, prohibition or unenforceability without invalidating the remaining provisions hereof, and any such invalidity, prohibition or unenforceability in any such jurisdiction shall not invalidate or render unenforceable such provision in any other jurisdiction.

Service

For Service or Technical Assistance: Contact your TLV representative or your regional TLV office.

In Europe:

TLV EURO ENGINEERING GmbH

Daimler-Benz-Straße 16-18, 74915 Waibstadt, **Germany**

Tel: [49]-(0)7263-9150-0
Fax: [49]-(0)7263-9150-50

TLV EURO ENGINEERING UK LTD.

Units 7 & 8, Furlong Business Park, Bishops Cleeve, Gloucestershire GL52 8TW, **U.K.**

Tel: [44]-(0)1242-227223
Fax: [44]-(0)1242-223077

TLV EURO ENGINEERING FRANCE SARL

Parc d'Ariane 2, bât. C, 290 rue Ferdinand Perrier, 69800 Saint Priest, **France**

Tel: 33-(0)4-72482222
Fax: [33]-(0)4-72482220

In North America:

TLV CORPORATION

13901 South Lakes Drive, Charlotte, NC 28273-6790, **U.S.A.**

Tel: [1]-704-597-9070
Fax: [1]-704-583-1610

In Mexico and Latin America:

TLV ENGINEERING S. A. DE C. V.

Av. Jesús del Monte 39-B-1001, Col. Hda. de las Palmas, Huixquilucan, Edo. de México, 52763, **Mexico**

Tel: [52]-55-5359-7949
Fax: [52]-55-5359-7585

In Oceania:

TLV PTY LIMITED

Unit 8, 137-145 Rooks Road, Nunawading, Victoria 3131, **Australia**

Tel: [61]-(0)3-9873 5610
Fax: [61]-(0)3-9873 5010

In East Asia:

TLV PTE LTD

36 Kaki Bukit Place, #02-01/02, **Singapore** 416214

Tel: [65]-6747 4600
Fax: [65]-6742 0345

TLV SHANGHAI CO., LTD.

Room 5406, No. 103 Cao Bao Road, Shanghai, **China** 200233

Tel: [86]-(0)21-6482-8622
Fax: [86]-(0)21-6482-8623

TLV ENGINEERING SDN. BHD.

No.16, Jalan MJ14, Taman Industri Meranti Jaya, 47120 Puchong, Selangor, **Malaysia**

Tel: [60]-3-8065-2928
Fax: [60]-3-8065-2923

TLV PRIVATE LIMITED

252/94 (K-L) 17th Floor, Muang Thai-Phatra Complex Tower B, Rachadaphisek Road, Huaykwang, Bangkok 10310, **Thailand**

Tel: [66]-2-693-3799
Fax: [66]-2-693-3979

TLV INC.

#302-1 Bundang Technopark B, 723 Pangyo-ro, Bundang, Seongnam, Gyeonggi, 13511, **Korea**

Tel: [82]-(0)31-726-2105
Fax: [82]-(0)31-726-2195

In the Middle East:

TLV ENGINEERING FZCO

Building 2W, No. M002, PO Box 371684, Dubai Airport Free Zone, Dubai, **UAE**

Email: sales-me@tlv.co.jp

In Other Countries:

TLV INTERNATIONAL, INC.

881 Nagasuna, Noguchi, Kakogawa, Hyogo 675-8511, **Japan**

Tel: [81]-(0)79-427-1818
Fax: [81]-(0)79-425-1167

Manufacturer:

TLV CO., LTD.

881 Nagasuna, Noguchi, Kakogawa, Hyogo 675-8511, **Japan**

Tel: [81]-(0)79-422-1122
Fax: [81]-(0)79-422-0112

Options

The options shown below are available for this product on request. Please compare with the product you received.

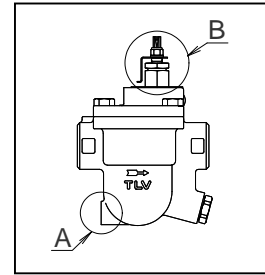

Options for Area A (standard: without drain plug)

With Drain Plug

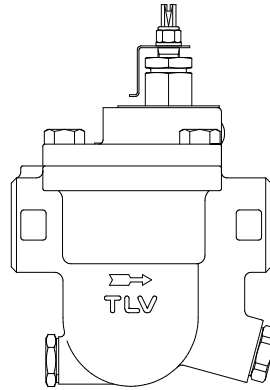

| Torque | | Distance Across Flats | |
|--------|----------|-----------------------|-----------------------------------|
| N·m | (lbf·ft) | mm | (in) |
| 35 | (26) | 21 | (¹³ / ₁₆) |

(1 N·m ≈ 10 kg·cm)

Options for Area B (standard: without handle)

With Handle

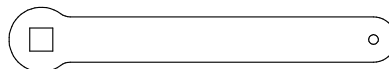

Length: 120 mm (4³/₄ in)

Distance Across Flats: 7 mm (⁹/₃₂ in)