



FLOATDYNAMIC® STEAM TRAP

MODEL JH15 CAST STEEL

HIGH CAPACITY CAST STEEL STEAM TRAP WITH FREE FLOAT PILOT MECHANISM

Features

High pressure, cast steel, inline maintainable, steam trap with free float and piston combination for discharge of high condensate flow rates. Suitable for large process heat exchangers.

1. Self-modulating free float pilot mechanism ensures discharge at near-to-steam temperatures.
2. Proven piston valve allows "pulsing" discharge of condensate at high flow rates and intermittent discharge at low flow rates.
3. Steam chamber design prevents damage to the valve and valve seat on closure.
4. All internal parts are easily accessible without having to remove the trap from the line.
5. Two built-in screens with large surface area ensure trouble-free operation.

Pressure Equipment Directive (PED)

Classification according to PED 2014/68/EU, fluid group 2

Size	Category	CE marking
DN 100	II	with CE marking and Declaration of Conformity



Specifications

Model	JH15E-21, JH15M-21, JH15S-21	JH15E-46, JH15M-46, JH15S-46
Connection	Flanged	
Size (DN)	DN 100	
Max. Operating Pressure (barg)	PMO 21	46
Max. Differential Pressure (bar)	ΔPMX 21	46
Min. Differential Pressure (bar)	0.5	
Max. Operating Temperature (°C)	TMO 400*/425	



To avoid abnormal operation, accidents or serious injury, do not use this product outside of the specification range. Local regulations may restrict the use of this product to below the conditions quoted.

PRESSURE SHELL DESIGN CONDITIONS (NOT OPERATING CONDITIONS): 1 bar = 0.1 MPa

Maximum Allowable Pressure (barg) PMA: 50

Maximum Allowable Temperature (°C) TMA: 400*/425

* With PN Flange

No.	Description	Material	DIN*	ASTM/AISI*
①	Body	Cast Steel A216 Gr.WCB	1.0619	—
②	Cover	Carbon Steel S25C	1.1158	AISI1025
③	Float	Stainless Steel SUS316L	1.4404	AISI316L
④	Float Screen	Stainless Steel SUS430	1.4016	AISI430
⑤	Float Cover	Stainless Steel SUS304	1.4301	AISI304
⑥	Cover Gasket	Graphite/Stainless Steel SUS304	— /1.4301	— /AISI304
⑦	Cover Bolt	Alloy Steel SNB16	1.7711	A193 Gr.B16
⑧	Cover Nut	Carbon Steel S45C	1.0503	AISI1045
⑨	Main Valve Screen, inside/outside	Stainless Steel SUS304/430	1.4301/1.4016	AISI304/430
⑩	Screen Cover	Cast Steel A216 Gr.WCB	1.0619	—
⑪	Screen Cover Gasket	Graphite/Stainless Steel SUS304	— /1.4301	— /AISI304
⑫	Screen Cover Bolt	Alloy Steel SNB7	1.7225	A193 Gr.B7
⑬	Screen Cover Nut	Carbon Steel S45C	1.0503	AISI1045
⑭	Valve Cover	Cast Steel A216 Gr.WCB	1.0619	—
⑮	Valve Cover Gasket	Graphite/Stainless Steel SUS304	— /1.4301	— /AISI304
⑯	Valve Cover Bolt	Alloy Steel SNB7	1.7225	A193 Gr.B7
⑰	Valve Cover Nut	Carbon Steel S45C	1.0503	AISI1045
⑱	Orifice	—	—	—
⑲	Orifice Gasket	Soft Iron SUYP	1.1121	AISI1010
⑳	Connector Pipe	Stainless Steel SUS304	1.4301	AISI304
㉑	Main Valve	—	—	—
㉒	Valve Seat	—	—	—
㉓	Cylinder	—	—	—
㉔	Piston Ring Set**	Carbon/Stainless Steel SUS304	— /1.4301	— /AISI304
㉕	Piston	Stainless Steel SUS303	1.4305	AISI303
㉖	Small Valve Seat Gasket	Graphite/Stainless Steel SUS304	— /1.4301	— /AISI304
㉗	Large Valve Seat Gasket	Graphite/Stainless Steel SUS304	— /1.4301	— /AISI304
㉘	Sleeve	Stainless Steel SUS420F	1.4028	AISI420F
㉙	Air Vent Valve Stem	Stainless Steel SUS304	1.4301	AISI304
㉚	Air Vent Valve Body	Stainless Steel SUS303	1.4305	AISI303
㉛	Air Vent Valve Gasket	Soft Iron SUYP	1.1121	AISI1010

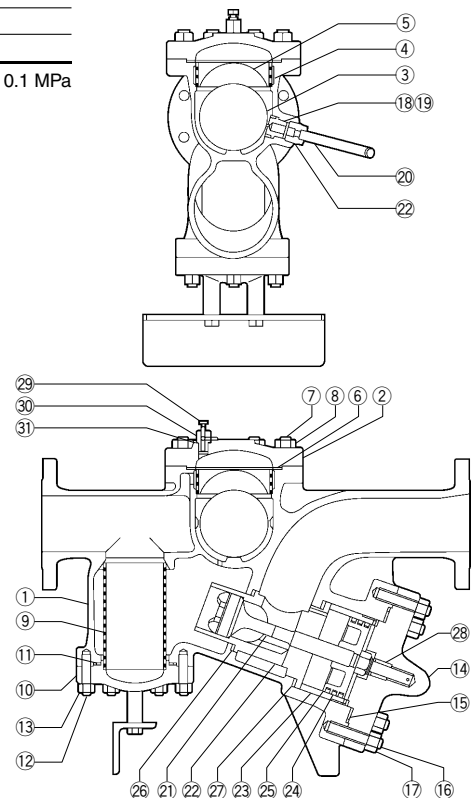

Copyright © TLV

* Equivalent materials ** 1 piston ring on JH15-21, 3 on JH15-46

Dimensions

● **JH15 Flanged**

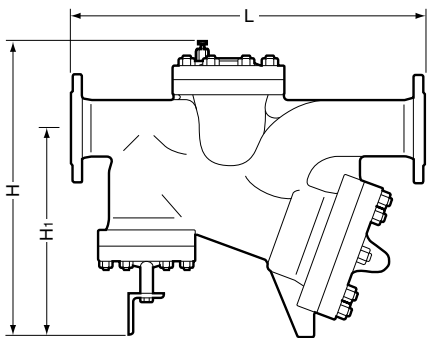
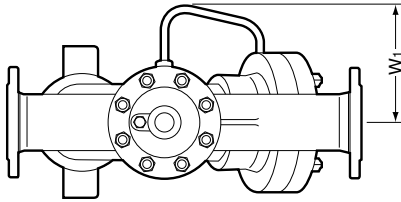

JH15 Flanged (mm)

Model	DN	L						H	H ₁	W ₁	Weight* (kg)
		DIN 2501			ASME Class						
		PN25/40	PN63	PN100	150RF	300RF	600RF				
JH15-21	100	—	—	—	750	—	635	440	250	171	
JH15-46		750	762	774	—	766					792

Other standards available, but length and weight may vary
 * Weight is for DIN PN 25/40, (PN 100)

Note: Piping Arrangement

- The horizontal piping sections should be sized according to the condensate load and velocity, without sharp bends, and using eccentric reducers for pipe size adjustment.
- A check valve must be installed on the outlet side.
- Install air bleed line and valve, and discharge safely to grade.
- Consult with TLV in case of difficulties with piping arrangement

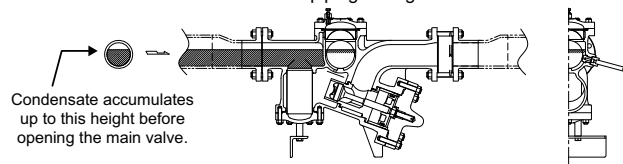

Inlet horizontal piping		Outlet piping**
Length (m)	Size (mm)	
1.0*	300*	Size the horizontal and vertical piping sections according to the condensate load and velocity. Use the TLV Engineering Calculator or ToolBox app, "Condensate Recovery Pipe Sizing for Condensate Recovery Line by Velocity" function. Recommended fluid velocities: • Flash steam: approx. 30 to 35 m/s • Condensate component: ≤ 2 m/s
1.25	250	
1.5	200	
2.5	150	
3.5	125	
5.0	100	

* Recommended by TLV ** Schedule 160 piping recommended

Discharge Capacity

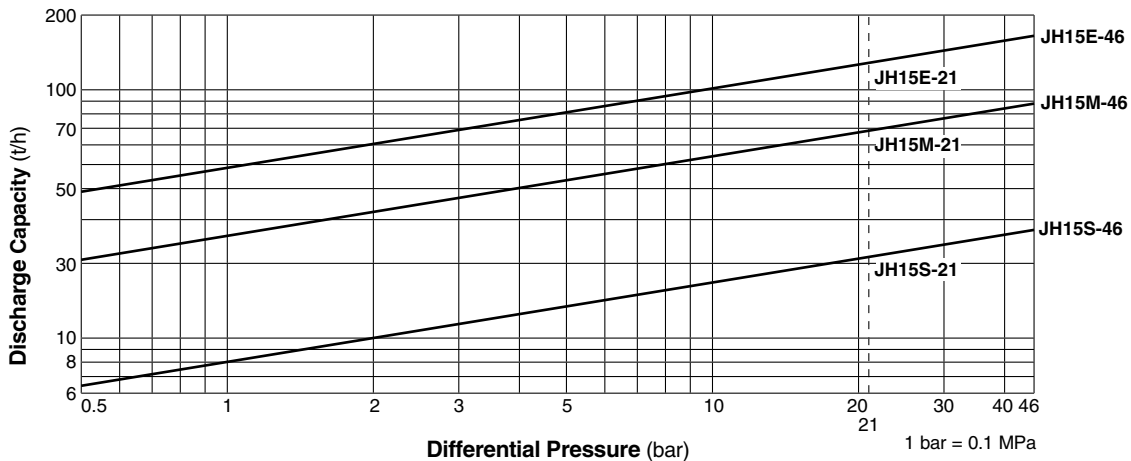

1. Differential pressure is the difference between the inlet and outlet pressure of the trap.
2. Capacities are based on continuous discharge of condensate 6°C below saturated steam temperature.
3. Select the closest model with a capacity greater than the actual condensate load multiplied by a safety factor of 1.2.



DO NOT use this product under conditions that exceed maximum differential pressure, as condensate backup will occur!

Manufacturer
TLV CO., LTD.
 Kakogawa, Japan
is approved by LRQA Ltd. to ISO 9001/14001

