

BV25064 | PN16 EN 1092-2

Nodular Cast Iron EN-GJS-400-18-LT



Testing pressure in bar

Temperature min. -10°C
Temperature max. +350°C

Hydro	Body	24
	Seat	18
Air	Seat	07

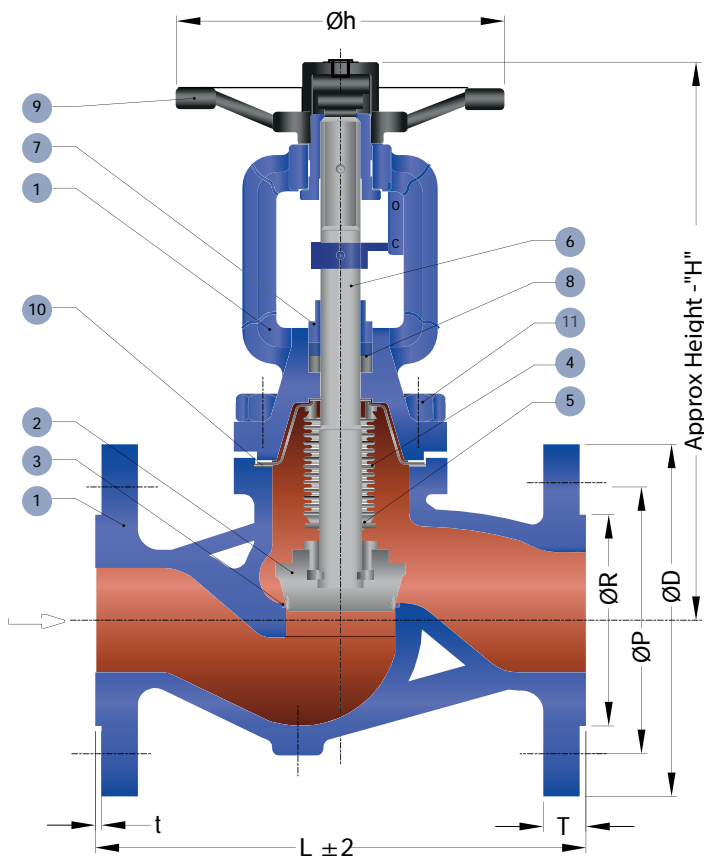

N°	COMPONENT	MATERIALS
1	Body & Bonnet	EN-GJS-400-18-LT Nodular Cast Iron
2	Plug	St. Steel 1.4021 + Hard Faced 13% Cr
3	Seat	ASTM - A105 + Hard Faced 13% Cr
4	Bellow	St. Steel 1.4541 / AISI-321
5	Bellow collar	St. Steel 1.4541
6	Stem	St. Steel 1.4006
7	Gland	St. Steel 1.4021
8	Packing	Pure Graphite
9	Hand Wheel	EN-GJS-400-18-LT Nodular
10	Bonnet Gasket	Graphite + Stainless steel
11	Bolt & Nuts	Carbon Steel Gr.10.9

ZERO LEAKAGE
DIN: Rate A acc.EN12266-1

Face to face dimensions acc. to EN558-1
Flanges acc. to EN 1092-2 form B

DN	PN	ØD (outer flange diameter)	ØP (Bolt circle)	ØR	T (FGL,THK)	t	NO.OF HOLE / Ø	L (Face to face)	Øh	STROKE	H (closed)	Weight (Kg)
15	16	95	65	46	16	2	4/Ø14	130	150	4	215	4,08
20	16	105	75	56	16	2	4/Ø14	150	150	5	220	5,16
25	16	115	85	65	17	3	4/Ø14	160	150	6.5	230	8,98
32	16	140	100	76	18	3	4/Ø19	180	150	8	235	7,80
40	16	150	110	84	19	3	4/Ø19	200	200	10	255	11,20
50	16	165	125	99	20	3	4/Ø19	230	200	13	265	13,06
65	16	185	145	118	20	3	4/Ø19	290	250	16,5	325	22,90
80	16	200	160	132	22	3	8/Ø19	310	250	20	335	27,40
100	16	220	180	156	24	3	8/Ø19	350	300	25	385	40,30
125	16	250	210	184	26	3	8/Ø19	400	350	32	425	67,20
150	16	285	240	211	26	3	8/Ø23	480	400	38	485	89,20
200	16	340	295	266	30	3	12/Ø23	600	450	51	615	143,50
250	16	400	355	319	32	3	12/Ø28	730	500	64	780	241,0
300	16	455	410	370	24.5	4	12/Ø28	850	600	76	970	410,00

all dimensions in mm.

WORKING CONDITIONS						
Temperature °C	-10/120	150	200	250	300	350
Pressure Bar	16	15,5	14,7	13,9	12,8	11,2